

BT



Working together

NORTEL

NORTHERN TELECOM

Completed forms should be returned to:
Northern House, Cambridge Business Park,
100 MARKET AVENUE, CAMBRIDGE
Applications: Tuesday 14th April

Business Development Opportunity

The right candidate must be able to:

- Enhance business efficiency
- Guide the company safely into the future
- Keep track of 100s of incoming calls
- Memorise hours of messages and who they're for
- Demonstrate a world class pedigree
- Be easy to work with and absolutely reliable
- Work 24 hours non-stop

Apply within...

HANERARTEL MANER is the world market leader in the design, manufacture and installation of relocatable partitions, chilled acoustic ceilings and wall storage systems. With manufacturing facilities in Europe, North America, Asia and 15 local divisions worldwide, the company can respond to all the needs of its mainly blue chip customer base. To further this dominant position the UK subsidiary, based in south-west London seeks today:

AREA MANAGERS

Working with an existing customer base of essential services and consumer companies in your sector, you will actively contribute to our number developing the brand. To create this real partnership with our clients you will be able to communicate at all levels, have a solid sales experience and before everything else be full of enthusiasm and ambition. In return we will offer you a care career opportunity, with training and a salary package with company car and benefits tailored to your position.

To apply, please send your CV + cover letter to: hr@haneratel.com and your telephone number to: 020 8711 1111.

...a group of...
...resources...
...This group...
...operations...
...and one...
...procedures...
...initial functions with...
...and reward qualified...
...
...experience leading in HR...
...company is required...
...HR experience with...
...reward systems is also...
...with collaborative style a plus...
...to Western...
...North, Midlands...
...telephone

090-096

ON RPT. develops, manufactures and markets data collection and data management products such as external and built-in decoders, hand-held scanners, portable data terminals, identification marks. They are destined for retail, education, manufacturing, healthcare and business development effects gather space across the following positions:

MANAGER UK
Data Collection
Excellent Package + car

With the Export Manager (France), you will focus on...
...to the UK via the expansion of our...
...responsibilities will include...
...budgets and forecasts...
...to help their...
...results and...
...abilities.

Norstar

M7208N Telephone User Card

...and...
...No. 2...
...1998

Your Norstar M7208N telephone

Display

shows the time, date, and call information; guides you while using Norstar features; tilts for easy viewing

Indicators

appear beside active lines and features

Release key

cancels active calls

Hold key

Feature key

starts or ends a feature

Keypad

Volume control

Memory and line keys

are keys with indicators for one-touch dialling, feature operation or line access



Using Key Inquiry

Check what is programmed on your memory keys.

1. Release all calls or lines with dial tone.
2. Press * 0 .
3. Press the key(s) that you want to check.
4. Read the display.
5. Press when finished.

Adjusting display contrast

1. Press * 7 .
2. Press to on the key pad for the contrast level you want; the higher the number the higher the contrast level.

Selecting a ring type and volume level

1. Press * 6 .
2. Press , , or to hear the different ring types.
3. While the telephone is ringing, press to adjust the volume level.
4. Press to store the ring.

Adjusting the handset or telephone speaker volume

1. Press when using the handset or the speaker.

Making and answering calls

Answering calls

Answering calls using the handset

When your telephone rings, or ► flashes beside an Intercom or line key:

1. Lift the handset.

OR

Press the key beside the flashing ► before lifting the handset.

Answering calls using Handsfree

When your telephone rings, or ► flashes beside an Intercom or line key:

1. Press .

Making calls

Depending upon the dialling mode programmed on your telephone, you may have to lift the handset before making a call.

External calls using numbered line keys

1. If you do not have an external Prime line, press a line key.

2. Dial your call.

External calls using Intercom keys

1. Lift the handset.

2. If ► appears beside an Intercom key, enter a line pool access code.

OR

Press an Intercom key without ►, then enter a line pool access code.

3. When you hear external dial tone, dial your call.

Internal calls using Intercom keys

1. If you do not have an internal Prime line, press .

2. Dial your call.

Note: Line pool access codes and extension numbers are supplied by your System Administrator.

Making calls using Handsfree

1. Press instead of lifting the handset.

Holding Calls

1. Press . The ► flashes beside the line on hold.

2. Press the line key with the flashing ► to return to the call.

Automatic hold

Calls are put on hold automatically when you switch from one line to another.

Exclusive hold

Use Exclusive Hold () to keep a call on hold so that it can be retrieved only at your telephone.

System Administrator can program Handsfree for your telephone.

Switching between Handsfree and handset

1. Press and replace the handset to switch to Handsfree.

2. Pick up the handset to switch back.

Using Mute

1. Press to turn the microphone OFF.

2. Press again to turn the microphone ON.

Setting up the telephone

Connecting the cords

1

Press here firmly until it clicks, to attach the stand.

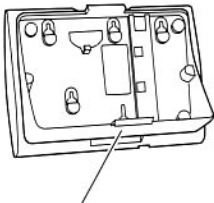

Press here to remove the stand.

2

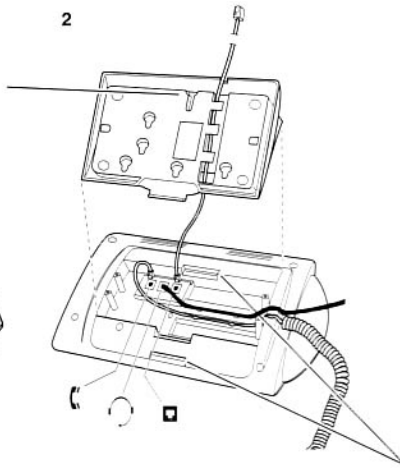

ATTENTION Before attempting to carry out **any** work on the telephone, ensure that the line cord is unplugged from the wall socket.

To remove any of the cords, squeeze the release latch on the plug and gently pull the plug from the socket.

Connect the handset cord to the jack labelled with the telephone icon and route the cord as shown.

If you are using a headset, route the cord along the channel in the base and connect the cord to the telephone jack that is marked with the headset icon.

Route the line cord through the stand and connect the cord to the telephone jack that is marked with the jack icon.

Attach the stand using either pair of slots; to raise the back of the telephone to its highest position, use these slots.

Once the above work is complete, plug the line cord back into its wall socket.

Mounting the telephone on the wall

See the next page for the illustrations.

1. Unplug the line cord from its wall socket.
2. Remove the stand.
3. Detach the handset clip from inside the stand (Panel 1).
4. Snap the handset clip into the two slots on the upper edge of the handset rest (Panel 2).
5. If you are using a headset, route the headset cord along the channel in the base and connect (as shown in panel 3) the cord to the telephone jack that is marked with the headset icon.
6. Route the line cord through the stand and connect the cord to the telephone jack that is marked with the jack icon.
7. Hold the telephone as shown in the illustration (panel 4), and position the stand with the wide end facing away from you. Insert the tab on the stand into the slot as indicated and press firmly until the stand clicks.
8. **IMPORTANT:** Lock the stand in place using two 2-mm screws (supplied) in the holes at both sides of the stand (as shown in panel 4). If you do not screw the stand on, the telephone may fall off the wall.
9. Insert two 4-mm x 2.5-cm long screws (not supplied) in the mounting surface (as shown in panel 5). Position the screws 12 cm apart horizontally. Ensure that the screw heads protrude from the mounting surface by 1 cm.
10. Position the telephone so that the screw heads slip into the slots on the back of the stand. Hold the telephone against the wall and slide it down until the screw heads are caught securely (as shown in panel 6).
11. Hang up the handset.
12. Plug the line cord back into its wall socket.

Setting up the telephone

1

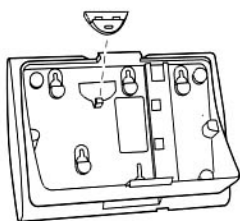

2



3

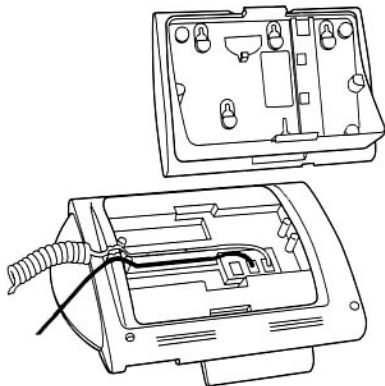

4

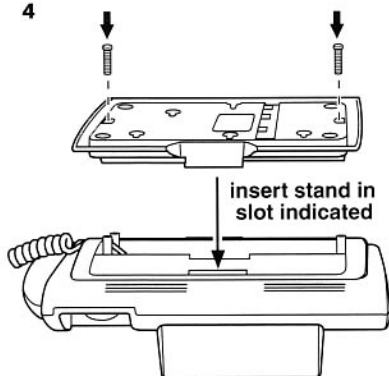

5

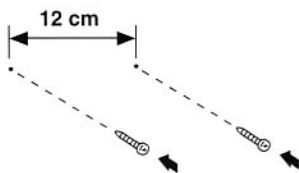

6



Programming memory keys

About memory keys



Memory keys are the keys with indicators other than line or Handsfree keys. Memory keys store telephone numbers or feature codes to give you one-touch dialling or feature activation. You can change what a memory key does by just programming it with a new number or feature. You cannot program a line or Handsfree key.

Remember: Press * to check a memory or line key.

Programming memory keys

External Autodial

1. If you are on a call or a line with dial tone, press or .
2. Press * .
3. Press a memory key.
4. Dial the external number.
5. Press to store the number.
6. Label your new key.

Internal Autodial

1. If you are on a call or a line with dial tone, press or .
2. Press * .
3. Press a memory key.
4. Dial the extension number.
5. Label your new key.

Features

1. If you are on a call or a line with dial tone, press or .
2. Press * .
3. Press a memory key.
4. Press and the feature code.
5. Label your new key.

Erasing memory keys

1. If you are on a call or a line with dial tone, press or .
2. Press * .
3. Press the memory key you want to erase.
4. Press to erase the key.

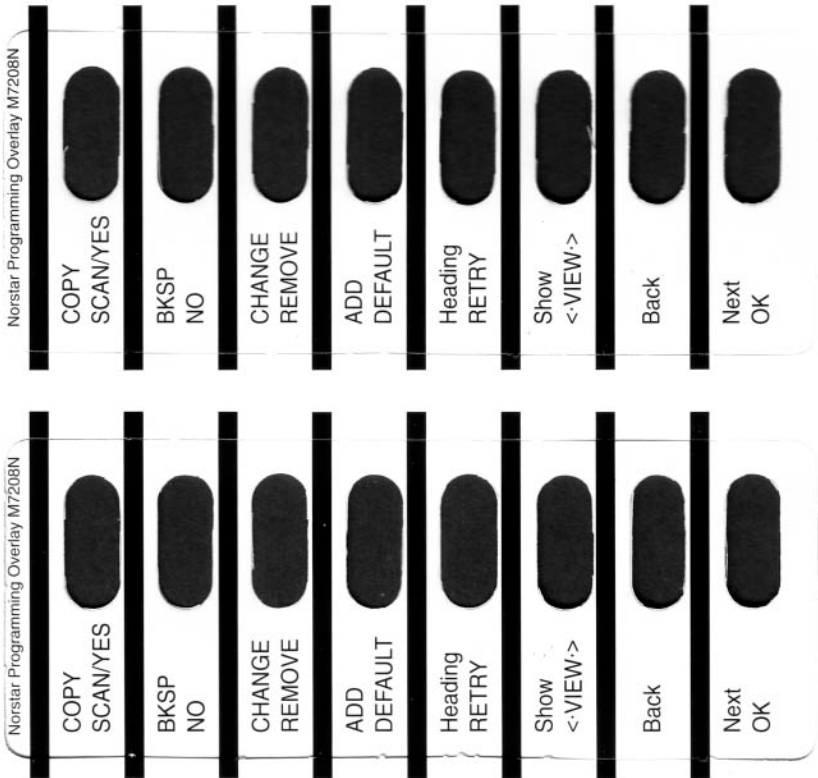

Note: Programming using the M7208N overlay is ONLY available with the Norstar Compact System.

Notice

These telephones now conform to the latest standards in relation to the positioning of Q and Z on the number keys. The Q appears on key number 7 and the Z appears on key number 9. Some earlier variants of Norstar and Norstar peripherals may expect these letters to appear on key number 0.